

1-step electric duct heater with controlling

ENG Technical documentation



1. Technical parameters:

V/Hz: 230/50

IP protection rating: 40

Set temperature range, °C: 0-30

Model	Min. airflow, m ³ /h	Nominal current, A	Heating power, kW
HEATER 150/1.2	120	5.3	1.2
HEATER 200/2.4	180	10.6	2.4
HEATER 250/2.4	265	10.6	2.4
HEATER 250/3.6	375	15.9	3.6

2. Construction:

The body of electric heater is made of galvanized plate which is good at high temperature resistance, heat reflection rate and corrosion resistance. There are two rubber seal ring installed at the end of the electric heater to make it easier to be connected with other ducts.

3. Installation:

The length of a straight pipe connecting the heater and an unit should be a bit higher than the distance to temperature sensor which should be equal or higher than three times diameter of this pipe (like it is shown on the picture below).

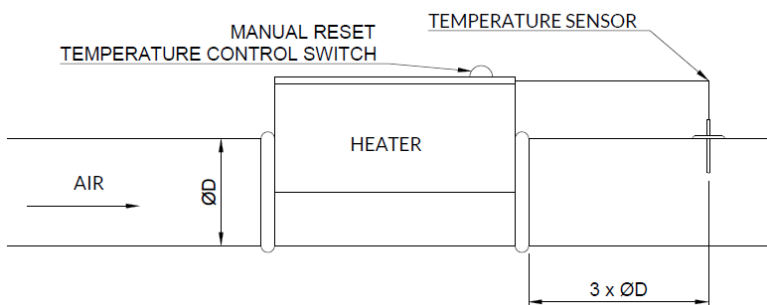

4. Operation:

The heater enables to achieve the required temperature of air after the heater (in the direction of airflow). It is realised by constant comparison of temperature measured by the temperature sensor with the one set by user with the temperature knob. Based on the difference, the controlling system of the heater adjust the heating capacity of the heater to achieve and maintain the required air temperature. It uses PWM method for it.

Moreover, in case of using item as a preheater, it is recommended to mount NTC temperature sensor in the exhaust duct and set temperature on the knob to 5°C.

5. Thermal protection:

All models are equipped with two-stage of temperature protection: automatically recover of 50°C temperature control switch and manual recover of 100°C temperature control switch.

Moreover, in case of connection to INSPIRO or VERTIC, if INSPIRO's or VERTIC's driver detects fan error, the connected heater would be turn off.

Attention: Before manually resetting the temperature control switch, the reason for the action of the temperature control switch should be found out, and the heater should be powered on again after the fault is eliminated.

6. Sensors:

For proper operation of the heater, the NTC temperature sensor must be connected. It is included in the set with the heater.

Moreover, there is an opportunity of applying an external differential pressure switch, which would prevent turning on the heater if there is no airflow. Such equipment should be installed in way measuring the pressure difference between sucking and blowing pipes). It is not included in set, its usage is optional.

7. Indicators:

There are three indicators located on PCB (see the diagram in point 9). The indicators tell about the state of the heater, i. e.:

D5 – fault indicator - it tells about a fault; if it is on, there is a problem with the differential pressure switch (if connected) or with the SCR; if the indicator is blinking, the probable cause is a short circuit of the SCR

D6 – power indicator - it tells that the heater is powered by electricity; it should be always on if the unit is supplied

D7 – heating indicator - it tells about the PWM duty cycle; it could steady on (if the duty cycle is 100%), steady off (if the duty cycle is 0%) or flash with an appropriate frequency (if the duty cycle higher than 0% and lower than 100%)

The state of the indicators should be verified during start up after the wiring of heater, in case of any failure and periodically as maintenance (at least two times per year).

8. Dimensions & Weights:

Model	ØD, mm	B, mm	H, mm	Weight, kg
HEATER 150/1.2	149	129	237	1.85
HEATER 200/2.4	199	129	287	2.40
HEATER 250/2.4	249	129	337	2.75
HEATER 250/3.6	249	129	337	3.15

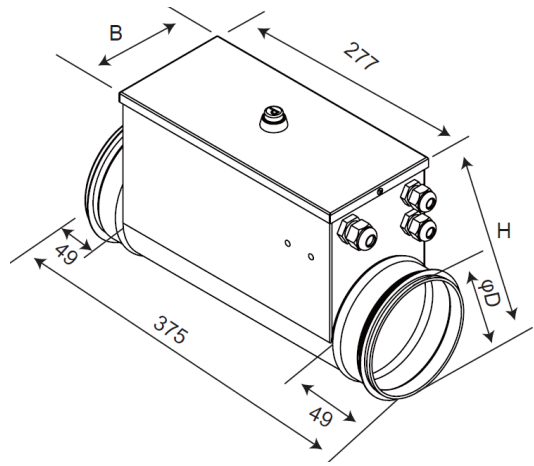

9. Wiring diagram:



WARNING: Please arrange the professional technician to install this product according to installation drawing and instruction.

RISK OF ELECTRICAL SHOCK: Disconnect power supply before making electrical connection. Contact with components carrying hazardous voltage can cause electrical shock and may result in severe personal injury or death.

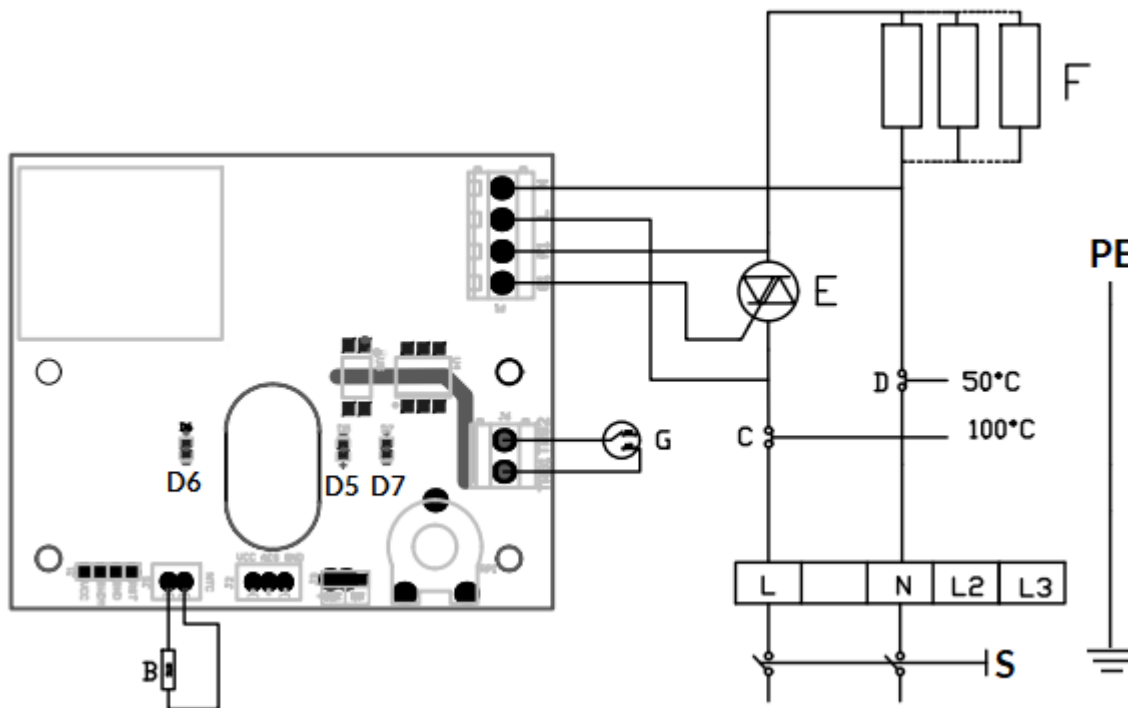

LEGEND FOR THE DIAGRAM

L, N - supply from the grid

PE - grounding it must be provided separately to the marked port on the housing

S - main switch, overcurrent circuit breaker and another installation protections (they should be done separately)

C - automatic thermal protection

D - manual thermal protection

F - heaters itself

E - thyristor (SCR)

G - differential pressure switch (optional)

B - NTC temperature sensor (obligatory; included in set)

D5, D6, D7 - indicators (see point 7 for details)

10. Warranty:

We offer the warranty of 24 months from the sales day. Please become acquainted with the Warranty Terms on the website

<http://www.reventongroup.eu/en/complaints>.